

INSTRUCTION MANUAL FOR

AC VOLTMETER

MODEL 1651A

KIKUSUI ELECTRONICS CORPORATION

7924  
20000

# Power Requirements of this Product

Power requirements of this product have been changed and the relevant sections of the Operation Manual should be revised accordingly.

(Revision should be applied to items indicated by a check mark )

Input voltage

The input voltage of this product is \_\_\_\_\_ VAC,  
and the voltage range is \_\_\_\_\_ to \_\_\_\_\_ VAC. Use the product within this range only.

Input fuse

The rating of this product's input fuse is \_\_\_\_\_A, \_\_\_\_\_VAC, and \_\_\_\_\_.

**WARNING**

- To avoid electrical shock, always disconnect the AC power cable or turn off the switch on the switchboard before attempting to check or replace the fuse.
- Use a fuse element having a shape, rating, and characteristics suitable for this product. The use of a fuse with a different rating or one that short circuits the fuse holder may result in fire, electric shock, or irreparable damage.

AC power cable

The product is provided with AC power cables described below. If the cable has no power plug, attach a power plug or crimp-style terminals to the cable in accordance with the wire colors specified in the drawing.

**WARNING**

- The attachment of a power plug or crimp-style terminals must be carried out by qualified personnel.

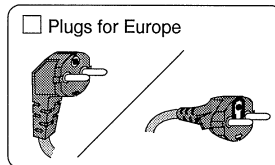
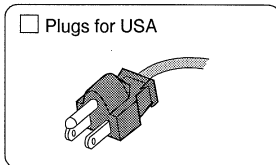
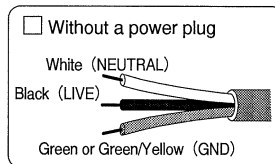
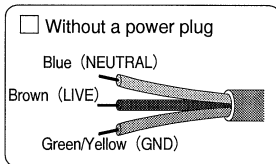

Provided by Kikusui agents

Kikusui agents can provide you with suitable AC power cable.  
For further information, contact your Kikusui agent.

Another Cable \_\_\_\_\_

TABLE OF CONTENTS

	<u>PAGE</u>
1. GENERAL .....	1
2. SPECIFICATION .....	2
3. OPERATION METHOD .....	5
3.1 Explanation of Panels .....	5
3.2 Preparations for Measurement .....	9
3.3 AC Voltage Measurement .....	10
3.4 AC Current Measurement .....	13
3.5 Output Measurement .....	14
3.6 Errors Caused by Waveform .....	14
3.7 Decibel Charts .....	15
3.8 AC Line Voltage Modification .....	22
4. OPERATING PRINCIPLE .....	23
4.1 Construction .....	23
4.2 Input Section .....	23
4.3 Latter-stage Attenuator .....	25
4.4 Main Amplifier .....	26
4.5 Meter Drive Circuit .....	26
4.6 Output Circuit .....	27
4.7 Power Supply .....	27
5. MAINTENANCE .....	28
5.1 Locations of Adjusting Potentiometers .....	28
5.2 Adjustment and Calibration .....	29
5.3 Troubleshooting .....	31

792284

## 1. GENERAL

The 1651A is a high-sensitivity AC voltmeter. It is compact, light, and consumes less power. The meter deflection is proportional to the mean value of the measured voltage.

The 1651A consists of a preamplifier, an impedance converter, a main amplifier, a meter drive circuit, an external output circuit, and a regulated power supply.

The overall measuring range is  $10 \mu\text{V} \sim 500 \text{ V}_{\text{rms}}$  ( $-100 \sim +56 \text{ dBm}$ ,  $-100 \sim +54 \text{ dBv}$ ), divided into 14 ranges with 10-dB steps in the manner of geometric progression. The frequency response is  $10 \text{ Hz} \sim 500 \text{ kHz}$ . The meter scale is linear with rms-equivalent values of sinusoidal wave.

The meter is incorporated with a 100-kHz low pass filter. The use of this filter is very advantageous when the signal source impedance is high.

The external output circuit provides an output voltage of about 1.5  $\text{V}_{\text{rms}}$  per meter full scale. With this provision the meter can be used also as an amplifier or a monitor of the measured signal.

## 2. SPECIFICATION

Instrument name: AC Voltmeter

Model No.: 1651A

Power requirements: 100 V AC, 50/60 Hz, approx. 4 VA  
(can be modified to 110, 117, 220, 230 or 240 V  
with internal connection change)

Dimensions: 134 W x 164 H x 270 D mm  
(Maximum dimensions): (140 W x 190 H x 325 D mm)

Weight: Approx. 3.2 kg (net)

Indicating meter: Scale length approx. 102 mm, full scale 1 mA,  
scales in 2 colors

### Scales

RMS scale (black): Rms-equivalent value of sinusoidal wave

dBm scale (red): Referenced to 1 mW, 600  $\Omega$

dBv scale (red): Referenced to 1.0 V, 0 dB

### Input circuit

Input terminals: UHF-type receptacle and GND terminal,  
19 mm (3/4") spacing

Input resistance: 10 M $\Omega$ , for all ranges

Input capacitance:

150 $\mu$ V ~ 1.5 V ranges	.....	40 pF or less
5 V ~ 500 V ranges	.....	30 pF or less

Maximum input voltages:

150  $\mu$ V ~ 1.5 V ranges: AC component 150 V (rms)  
 $\pm$ 200 V (peak)  
5 V ~ 500 V ranges: AC component 500 V (rms)  
 $\pm$ 700 V (peak)  
DC component (all ranges):  $\pm$ 400 V

Scale ranges: 14 ranges

RMS scale: 150/500  $\mu$ V  
1.5/5/15/50/150/500 mV  
1.5/5/15/50/150/500 V

dBm and dBv scales: -80/-70/-60/-50/-40/-30/-10  
0/10/20/30/40/50 dB

Accuracy:  $\pm$ 3% FS, at 1 kHz

Stability: 0.2% FS or better, for  $\pm$ 10% variation of line  
voltage

Temperature coefficient: 0.05%/°C, at 1 kHz

Frequency response: 10 Hz ~ 500 kHz .....  $\pm$ 5%  
20 Hz ~ 200 kHz .....  $\pm$ 3%

Internal filter: 100 kHz low pass filter  
(The filter is connected in the circuit only  
when the 100 kHz pushbutton switch is depressed,  
and the meter indication and external output  
signal are reduced by approximately 3 dB at  
100 kHz.)

Noise: (With input terminals shorted)

Range	Filter in	Filter out
500 $\mu$ V ~ 500 V	1% FS or less	1% FS or less
150 $\mu$ V	2% FS or less	4% FS or less

Filter in: When 100 kHz filter is connected

Filter out: When 100 kHz filter is disconnected

The noise affects the indicated value as follows:

$$\text{Indicated value} = \sqrt{(\text{Signal value})^2 + (\text{Noise})^2}$$

#### Output circuit

Output terminals: 5-WAY type, 19 mm (3/4") spacing

Output impedance: Approx. 600  $\Omega$

Output voltage: About 1.5 Vrms at meter FS

Distortions: 2% or less, at FS, 1 kHz, 15 mV

Frequency response: 7 Hz ~ 250 kHz, +1 ~ -3 dB  
(with 10 M $\Omega$  resistor and 50 pF capacitor  
connected to output terminals)

Accessories: 941B Terminal Adaptor ..... 1  
Instruction Manual ..... 1

### 3. OPERATION METHOD

#### 3.1 Explanation of Panels

##### 3.1.1 Explanation of Front Panel

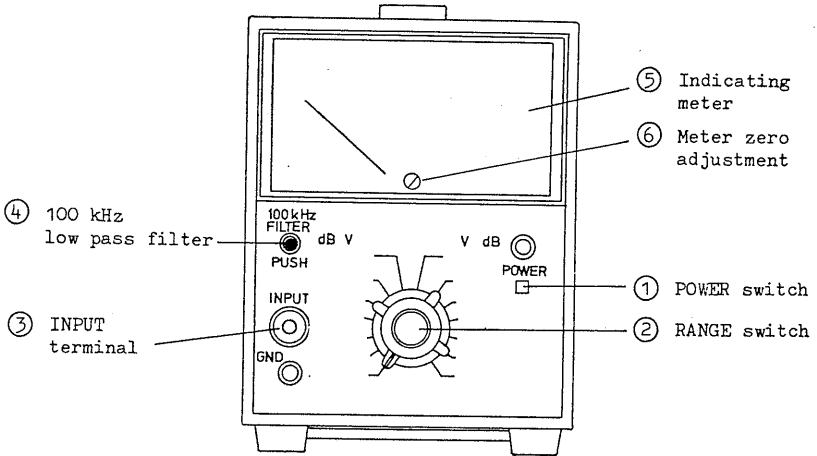

Fig. 3-1

① POWER switch:

Pushbutton switch for instrument power ON-OFF.  
Depressed and locked state is ON; pressed again and  
popped-up state is OFF.

Meter pointer may deflect irregularly for about 10  
seconds after turning-ON the instrument power. The  
deflection is transient and not an abnormal sign  
of instrument.

702289



② RANGE switch:

Selects the measuring range. Dial figures are full-scale voltage values (black) or dB values (red). The range becomes higher as this switch is turned clockwise.

To prevent overload to the instrument, start measurement with higher ranges and gradually turn the switch to lower ranges, observing the meter deflection.

③ INPUT terminals:

Consist of UHF-type receptacle and GND terminal. Connection can be conveniently done with UHF-type (5/8" - 24) or M-type (16 - 1F) plug or with standard twin banana plugs (19 mm = 3/4" spacing).

An appropriate banana plug may be used for connection with the inner conductor of the receptacle. It also is possible to insert "Model 941B Terminal Adaptor" (supplied) in the receptacle and connect to this adaptor a banana plug, spade lug, alligator clip, 2-mm chip, or lead wire of 2 mm or less.

The outer conductor of receptacle and the GND terminal are connected to instrument chassis and panel.

④ 100 kHz filter:

As you press this pushbutton switch to the depressed state (filter-in state), the 100 kHz low pass filter (-3 dB at 100 kHz) is connected to the circuit. As you press the button again, it is reset to the popped-up state (filter-out state) and the filter is disconnected from the circuit.

Frequency response of meter indication when in the filter-in state is shown in Fig. 3-2.

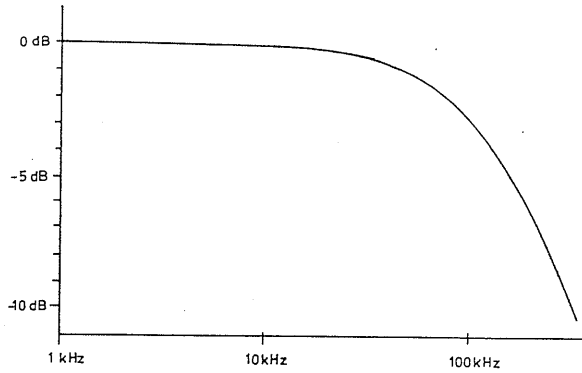

Fig. 3-2

⑤ Meter scales:

The indicating meter has four scales as follows, in the order of from outside to inside.

1. "15" scale: For 150  $\mu$ V, 1.5/15/150 mV and 1.5/15/150 V ranges
2. "50" scale: For 500  $\mu$ V, 5/50/500 mV and 5/50/500 V ranges
3. "dBv" scale: In dBv value with reference to 1.0 V as 0 dBv. For all of 14 ranges covering -80 dB to 50 dB.
4. "dBm" scale: In dBm value with reference to 1 mW, 600  $\Omega$ . For all of 14 ranges covering -80 to 50 dB.

⑥ Meter zero adjustment:

Mechanical zero adjustment of the indicating meter.  
Be sure to turn-OFF the POWER switch before adjusting mechanical zero of the meter. (To ensure this, turn-OFF the POWER switch and wait about 5 minutes so that the meter pointer is perfectly settled.)

3.1.2 Explanation of Rear Panel

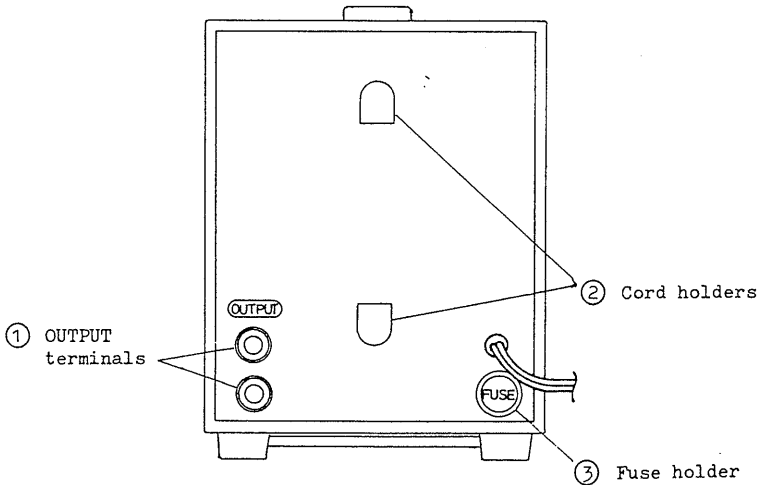

Fig. 3-3

① OUTPUT terminals:

Provides the output signal for using the instrument as an amplifier. For connection, twin banana plugs are convenient. Connection can also be done with banana plug, spade lug, alligator clip, 2-mm chip, or lead wire of 2 mm or less, as is the case for Type 941B Terminal Adaptor.

792292

② Cord holders:

The power cord is wound on these hooks when the instrument is not in use.

③ Fuse holder:

Fuse holder of the primary circuit of the power transformer. To replace the fuse, turn the cap counterclockwise.

### 3.2 Preparations for Measurement

- 1) Turn-OFF the POWER switch.
- 2) Check that the meter pointer is indicating the zero scale position. If it has been shifted, align it accurately with the zero position by means of the meter zero adjustment ⑥. (See Fig. 3-1.) (Before adjusting the mechanical zero, ensure that the meter pointer has been settled near the zero position as a period of 5 minutes of thereabove has elapsed after turning-OFF the POWER switch.)
- 3) Connect the power cord to an AC line outlet of the correct voltage and frequency (100 V AC, 50/60 Hz for unmodified instrument).
- 4) Set the RANGE switch in the 50 dB position.
- 5) Turn-ON the POWER switch. The LED lamp of the switch will light. The meter pointer may deflect at random for about 10 seconds when the POWER switch is turned ON or OFF. This is only transient and not an abnormal indication.
- 6) When the pointer is stabilized, the instrument is ready for measurement.

792293

- 7) For measurement at a high sensitivity, connect the 100-kHz low pass filter (-3 dB at 100 kHz) by depressing pushbutton (4) of Fig. 3-1, in order that the input signal can be measured with low noise. This feature is especially advantageous when the signal source impedance is high.

### 3.3 AC Voltage Measurement

- 1) Use either the "1" or "3" scale. The scale factors and measuring units are as shown in table 3-1.

Range	Scale	Scale factor	Measuring unit
150 $\mu$ V -80 dB	15	10	$\mu$ V
500 $\mu$ V -70 dB	50	10	$\mu$ V
1.5 mV -60 dB	15	0.1	mV
5 mV -50 dB	50	0.1	mV
15 mV -40 dB	15	1	mV
50 mV -30 dB	50	1	mV
150 mV -20 dB	15	10	mV
500 mV -10 dB	50	10	mV
1.5 V 0 dB	15	0.1	V
5 V 10 dB	50	0.1	V
15 V 20 dB	15	1	V
50 V 30 dB	50	1	V
150 V 40 dB	15	10	V
500 V 50 dB	50	10	V

Example: Assume that the RANGE switch is in the 50 V position and the meter reading is 45 on the "50" scale. In this case the measured voltage is 45 V. If the RANGE switch is in the 500 mV position, the measured voltage is  $450 \text{ mV} = 0.45 \text{ V}$ .

Assume that the RANGE switch is in the 15 V position and the meter reading is 9 on the "15" scale, the measured voltage is 9 V. If the RANGE switch is in the 150 mV position, the measured voltage is 90 mV.

- 2) For dBm measurement, use the "dBm" scale in common for all ranges. The "0" position in the center of the scale represents the level of the range name. Add to this level the dB value read on the scale.

Example 1: Assume that the meter reads 2 on the "dBm" scale with the 30 dB (50 V) range. The signal level in this case is

$$2 + 30 = 32 \text{ dB.}$$

Example 2: Assume that the same signal is measured with the 40 dB range. The meter should read -8 dBm and the signal level is

$$-8 + 40 = 32 \text{ dB.}$$

Example 3: Assume that the meter reads -1 dBm with the -20 dB (150 mV) range. The signal level in this case is

$$-1 + (-20) = -21 \text{ dBm}$$

Example 4: Assume that the same signal is measured with the -10 dB (500 mV) range. The meter should read -11 dBm and the signal level is

$$-11 + (-10) = - (11 + 10) = -21 \text{ dBm}$$

Further explanation on dBm is given at a later part of this instruction manual.

3) For dBv measurement, use the "dBv" scale in common for all ranges. The measuring method is the same as above.

Example 1: Assume that the meter reads -2 on the "dBv" scale with the 30 dB (50 V) range. The signal level is

$$-2 + 30 = 28 \text{ dBv}$$

Example 2: Assume that the same signal is measured with the 40 dB range. The meter should read -12 dBv and the signal level is

$$-12 + 40 = 28 \text{ dBv}$$

Example 3: Assume that the meter reads -5 dBv with the -20 dB (.150 mV) range. The signal level is

$$-5 + (-20) = -25 \text{ dBv}$$

Example 4: Assume that the same signal is measured with the -10 dB (500 mV) range. The meter should read -15 dBv and the signal level is

$$-15 + (-10) = -25 \text{ dBv}$$

792296

### 3.4 AC Current Measurement

An AC current can be measured by feeding the current through a resistor (non-induction type) and determining with this AC voltmeter the voltage drop developed across the resistor, by using Ohm's law as follows:

$$I = E/R$$

In this measurement, note that one of the input terminals is grounded.

Example: Measurement of heater current (nominal 6.3 V, 0.3 A) of vacuum tube

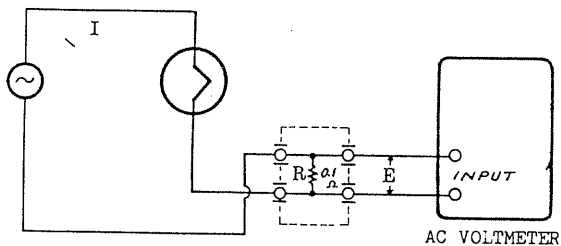

Fig. 3-4

Assume that the voltage measured across resistor R of Fig. 3-4 is 29 mV. The current can be known as follows:

$$I = \frac{29 \times 10^{-3}}{0.1} = 290 \times 10^{-3} = 290 \text{ mA}$$

792297



### 3.5 Output Measurement

Apparent power VA of impedance X can be known by measuring voltage E developed across the impedance as follows:

$$VA = E^2/X$$

If the impedance is purely resistive, power P consumed in the impedance can be calculated as follows:

$$P = E^2/R$$

Since the 1651A has a dBm scale, the power can be read provided that R = 600  $\Omega$ .

Even when the load resistance is 1  $\Omega$  ~ 10 k $\Omega$ , the power can be known in a dB value by adding a value obtained by using the decibel chart of Fig. 3-5 or 3-6.

### 3.6 Errors Caused by Waveform

The 1651A is a "mean-value indicating meter" and its pointer deflects in proportion to the mean value of its input voltage, while its scale is calibrated with the rms value of sinusoidal wave. Therefore, errors can be caused by waveform distortions of the input signal. The relationship of waveform distortions vs. meter indications is shown in Table 3-2.

792298

Table 3-2

Input signal	Rms value	Meter indication
Fundamental wave of 100% amplitude	100%	100%
100% fundamental wave + 10% 2nd harmonic	100.5%	100%
100% fundamental wave + 20% 2nd harmonic	102%	100 ~ 102%
100% fundamental wave + 50% 2nd harmonic	112%	100 ~ 110%
100% fundamental wave + 10% 3rd harmonic	100.5%	96 ~ 104%
100% fundamental wave + 20% 3rd harmonic	102%	94 ~ 108%
100% fundamental wave + 50% 3rd harmonic	112%	96 ~ 116%

### 3.7 Decibel Charts

#### 1) Decibel (dB)

Decibels indicate the ratio between two powers ( $P_1$  and  $P_2$ ) with the natural logarithm as follows:

$$\text{dB} = 10 \log_{10} \frac{P_2}{P_1}$$

When the impedances of the circuits where  $P_1$  and  $P_2$  exist are equal, decibels are used also to represent ratios in voltage or current as follows:

$$\text{dB} = 20 \log_{10} \frac{E_2}{E_1}$$

$$\text{dB} = 20 \log_{10} \frac{I_2}{I_1}$$

Though originally were for ratios in power, decibels have become to be used, since quite long ago, also for representing ratios in voltage and current.

Assume that the input voltage of an amplifier is 10 mV and the output voltage is 10 V. The gain of this amplifier is 10 V/100 mV = 1000 times. In dB value, the gain is expressed as follows:

$$\text{Gain} = 20 \log_{10} \frac{10 \text{ V}}{10 \text{ mV}} = 60 \text{ (dB)}$$

The output voltage of an RF signal generator may be given in terms of dB with respect to 1  $\mu$ V. An output signal voltage of 10 mV, for example, is expressed as follows:

$$10 \text{ mV} = 20 \log_{10} \frac{10 \text{ mV}}{1 \mu\text{V}} = 80 \text{ (dB)}$$

For such decibel representations, their reference levels (0 dB levels) should be indicated. For the above example, indication should be as 10 mV = 80 dB (1  $\mu$ V = 0 dB) where the note enclosed in the parentheses indicates the reference level.

## 2) dBm

Term "dBm" stands for "dB (mW)" and is used to represent power ratios referenced to 1 mW as 0 dB. This term often is used implying that the impedances of the circuits where the powers occur are 600 ohms. To be more accurate, the expression for such cases should be as "dB (mW 600 $\Omega$ )".

Thus, when powers and impedances are given, ratios in voltage and current also can be expressed as in power. Term "dBm" is used being referenced to the following physical quantities.

$$0 \text{ dBm} = 1 \text{ mW or } 0.775 \text{ V or } 1.291 \text{ mA}$$

792300

Since the "dBm" scale of the 1651A is graduated with dBm values defined as above, the meter reading should be converted when measurement is to be done in terms of a dBm value which is referenced to a value other than the above 0 dBm value (1 mW, 600  $\Omega$ ). Due to the nature of the logarithm, conversion calculation can be accomplished through simple addition or subtraction. The decibel charts of Figs. 3-5 and 3-6 are used for this purpose.

### 3) How to Use the Decibel Charts

Fig. 3-5 shows a chart for converting ratios in power, voltage or current into decibel values. Different scales are used according to whether the ratio of two powers (or equivalents) or that of two voltages or currents is to be calculated.

Example 1: What is 5 mW in dB value reference to 1 mW?

Since the ratio is in power, use the left-hand side scale. Calculate  $5 \text{ mW}/1 \text{ mW} = 5$  and find the dB value to be 7, following the dotted line.

Example 2: What are 50 mW and 500 mW in dB values referenced to 1 mW?

When the ratio is smaller than 0.1 or larger than 10, find figures in Table 3-3 and add the figures found.

$$50 \text{ mW} = 5 \times 10 = 7 + 10 = 17 \text{ dB}$$

$$500 \text{ mW} = 5 \times 100 = 7 + 20 = 27 \text{ dB}$$

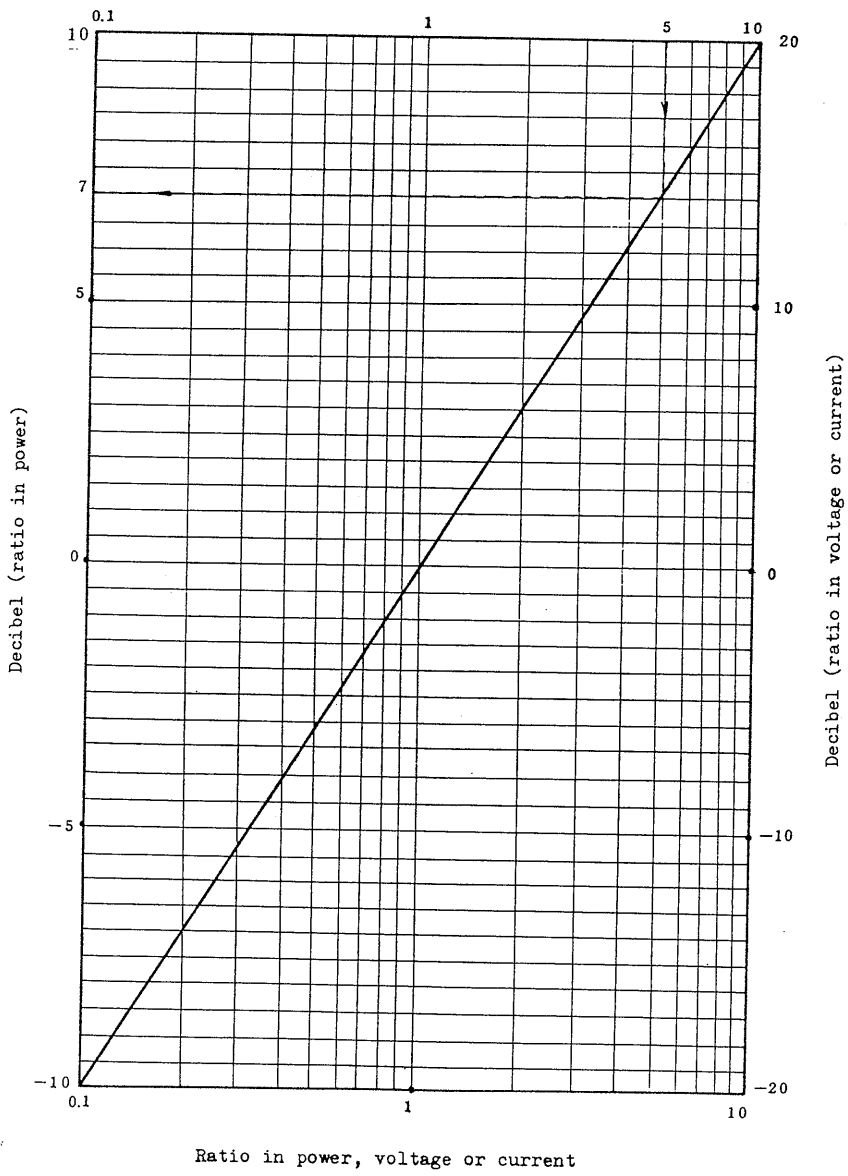

Fig. 3-5

792302

Table 3-3

Ratio	Decibel	
	Power ratio	Voltage or current ratio.
$10,000 = 1 \times 10^4$	40 dB	80 dB
$1,000 = 1 \times 10^3$	30 dB	60 dB
$100 = 1 \times 10^2$	20 dB	40 dB
$10 = 1 \times 10^1$	10 dB	20 dB
$1 = 1 \times 10^0$	0 dB	0 dB
$0.1 = 1 \times 10^{-1}$	-10 dB	-20 dB
$0.01 = 1 \times 10^{-2}$	-20 dB	-40 dB
$0.001 = 1 \times 10^{-3}$	-30 dB	-60 dB
$0.0001 = 1 \times 10^{-4}$	-40 dB	-80 dB

Example 3: What is 15 mV in dB(V) value?

Since referenced to 1 V, calculate at first as  $15 \text{ mV}/1 \text{ V} = 0.015$  and, next, calculate using the voltage and current scale as follows:

$$0.015 = 1.5 \times 0.01 \rightarrow 3.5 + (-40) = -36.5 \text{ dB(V)}$$

Or, in the reverse of the above, calculate as follows:

$$1 \text{ V}/15 \text{ mV} = 66.7$$

$$66.7 = 6.67 \times 10 \rightarrow 16.5 + 20 = 36.5 \text{ dB(V)}$$

$$-36.5 \text{ (dB(V))}$$

792303

4) Decibel Addition Chart

To convert the dBm reading into a power value, use the chart of Fig. 3-6.

Example 1: Assume that the meter reading is  $-4.8$  dBm as measured across an  $8$ -ohm speaker voice coil. Calculate the power (apparent power, to be more accurate) fed to the coil?

Using the chart of Fig. 3-6, find the value of  $-18.8$  for  $8$  ohms as indicated with the dotted line. Add this value to the meter reading to know the value for the dB (mW,  $8\Omega$ ) indication.

$$\text{dB (mW, } 8\Omega) = -4.8 + 18.8 = +14$$

To convert  $14$  dB (mW,  $8\Omega$ ) into a power value, use Fig. 3-5 and find the value to be  $25$  mW.

Example 2: What voltage is required to be applied to a  $10$  k $\Omega$  resistor to obtain a power of  $1$  W?

As  $1$  W is  $1000$  mW and is equivalent to  $30$  dB(mW), the answer can be known by calculating the voltage for  $30$  dB(mW,  $10\text{k}\Omega$ ). Referring to Fig. 3-6, the addition calculation of  $600\ \Omega \rightarrow 10\ \text{k}\Omega$  results in  $-12.2$  and, therefore, the meter should indicate  $30 - (-12.2) = 42.2$  on the dB (mW,  $600\Omega$ ) scale. The voltage which causes meter indication of  $42.2 - 40 = 2.2$  dBm is the answer and this voltage can be found to be  $42.2$  dBm =  $100$  V.

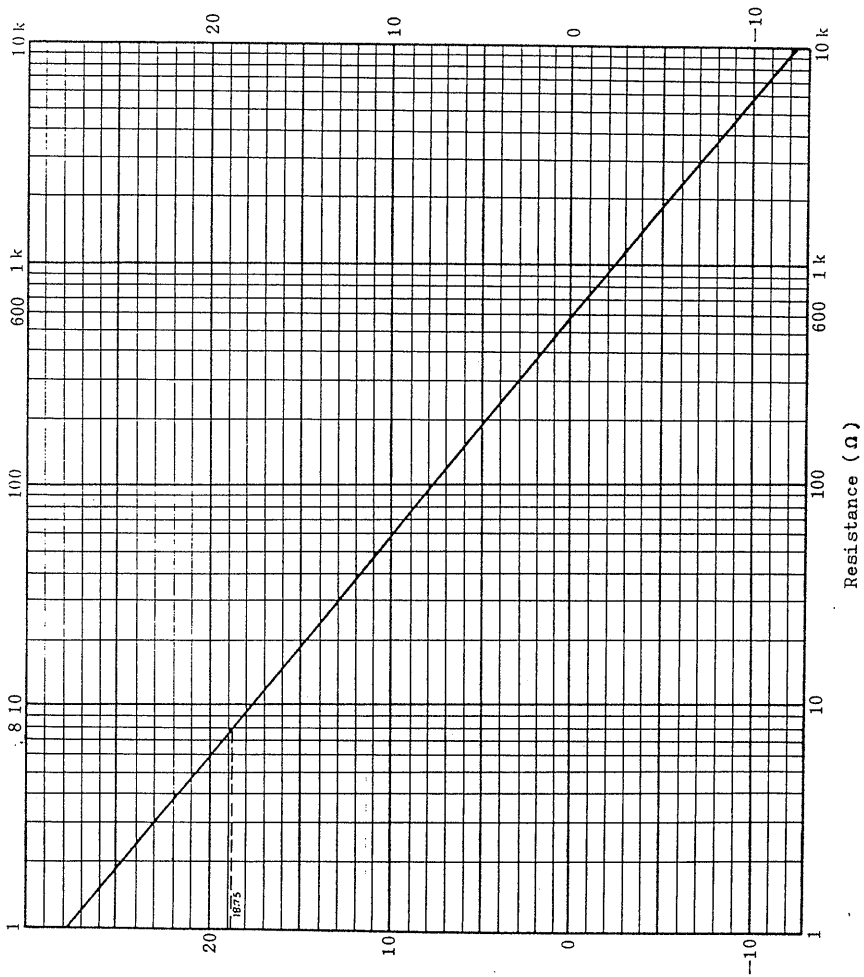

Addition chart (dB)

Resistance (Ω)

Fig. 3-6

792305



### 3.8 AC Line Voltage Modification

The 1651A can be modified for operation on a 100, 117, 220, 230, or 240 V AC power. For this modification, disconnect No. 1 tap wire (brown, normally) of the 3-pin terminals of the transformer at the rear panel, and connect the required tap wire referring to Table 3-4.

Table 3-4

AC line voltage	Tap wire No.	Wire color
110 V	2	Red
117 V	3	Orange
220 V	4	Yellow
230 V	5	Green
240 V	6	Blue

Note: Colors of wires subject to change without notice.  
Be sure to check the transformer tap wire number.

792306

#### 4. OPERATING PRINCIPLE

##### 4.1 Construction

The 1651A AC Voltmeter consists of an input section (a pre-amplifier, a former-stage attenuator, an impedance converter), a latter-stage attenuator, a main amplifier, an output circuit, and a power supply circuit.

##### 4.2 Input Section

(a) -80 ~ -50 dB ranges:

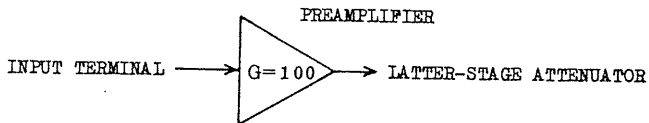

Fig. 4-2

As shown in Fig. 4-2, the input signal is sent to the latter-stage attenuator after being amplified by 100 times by the preamplifier.

(b) -40 ~ 0 dB ranges:

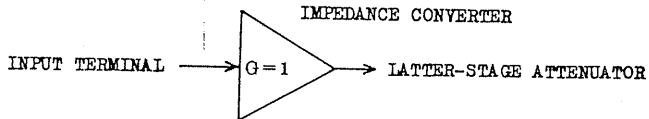

Fig. 4-3

As shown in Fig. 4-3, the input signal is sent to the latter-stage converter through the impedance converter.

792307

792308

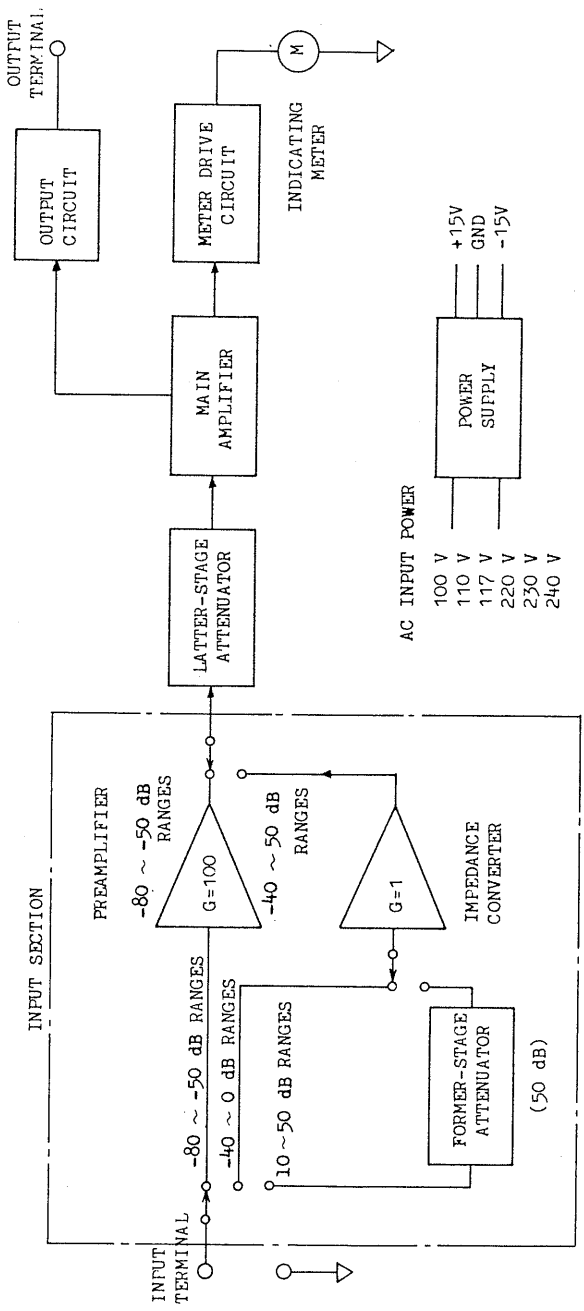

Fig. 4-1 Block diagram of the AC Voltmeter

(c) 10 ~ 50 dB ranges:

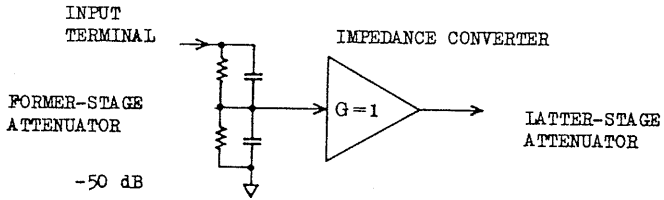

Fig. 4-4

As shown in Fig. 4-4, the input signal is sent to the latter-stage attenuator through the former-stage attenuator (50 dB) and impedance converter.

#### 4.3 Latter-stage Attenuator

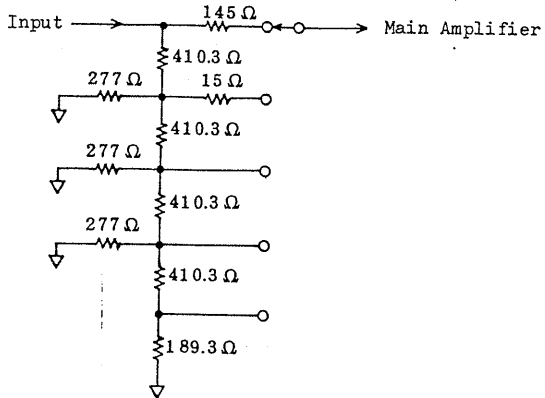

Fig. 4-5

The input signal is attenuated in 10-dB steps (0/10/20/30/40 dB) with the latter-stage attenuator as shown in Fig. 4-5.

7922000

#### 4.4 Main Amplifier

The main amplifier amplifies the output signal of the latter-stage attenuator. This amplifier is a negative-feedback amplifier consisting of three transistors ( $Q_{11} \sim Q_{13}$ ). Its gain is approximately 20 dB. Its output is sent to the indicating meter drive circuit and to the external output circuit.

#### 4.5 Meter Drive Circuit

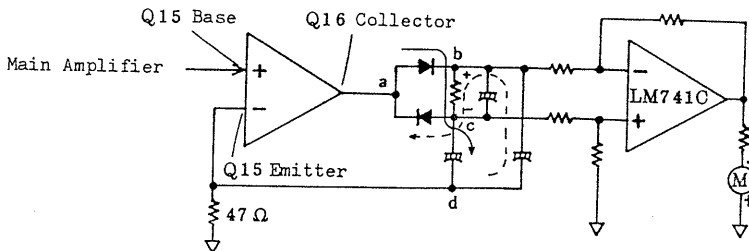

Fig. 4-6

The meter drive circuit has transistors ( $Q_{15}$  and  $Q_{16}$ ) and  $IC_3$ . A feedback current flows from the collector of transistor  $Q_{16}$  to the emitter through the rectifying diodes. Due to this feedback, the diodes are driven with almost constant currents and their non-linearity is compensated for and, consequently, the meter deflection becomes linear. This principle is shown in Fig. 4-6. For the positive half-cycles of the amplifier output voltage (point a: collector of  $Q_{16}$ ), the current flows in the circuit of  $a \rightarrow b \rightarrow c \rightarrow d$  as indicated with the solid line; for the negative half-cycles, the current flows in the circuit of  $d \rightarrow b \rightarrow c \rightarrow a$  as indicated with the dotted line. Between b and c, the rectified current flows in the polarity as shown in Fig. 4-6. This DC voltage is amplified and fed to the indicating meter.

#### 4.6 Output Circuit

The collector signal of transistor  $Q_{12}$  of the main amplifier is amplified by transistor  $Q_{14}$  and the amplified signal is fed to the output terminal with a 600-ohm output impedance. The output signal is approximately 1.5 V for the meter full scale.

#### 4.7 Power Supply

The power supply provides the regulated +15 V and -15 V supplies. Both supply circuits use the same type of voltage regulator IC.

792311

## 5. MAINTENANCE

### 5.1 Locations of Adjusting Potentiometers

Locations of the adjusting potentiometers are shown in Figs. 5-1 and 5-2. To gain access to these potentiometers, remove the top casing after removing the two clamping-screws, remove the top, right and left panels, and remove the bottom casing after removing the four clamping-screws at the bottom panel.

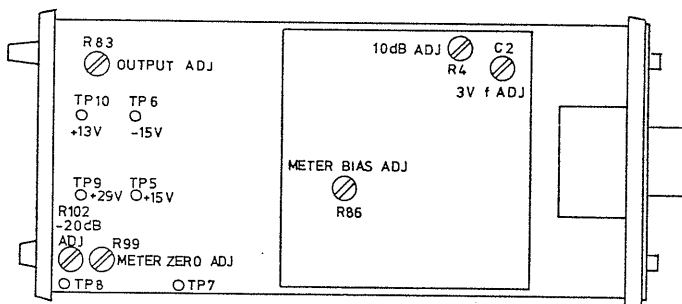
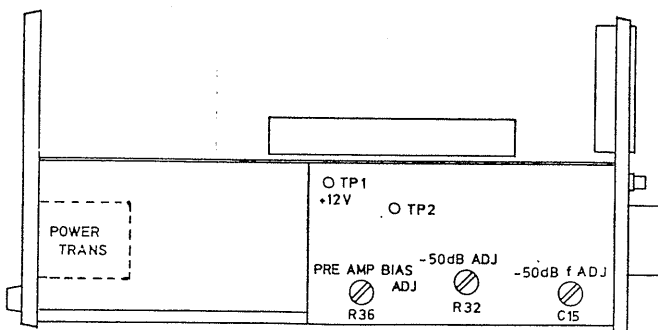

Fig. 5-1 Top view



Gig. 5-2 Side view

792312

## 5.2 Adjustment and Calibration

When the instrument has become not satisfying its specification after a long time of use or a repair, it must be adjusted and calibrated following in the due order the procedures explained in this section.

### 1) Check of regulated voltage circuit:

Check the voltages of the test points with respect to the GND, and shown in Table 5-1.

Test point	Voltage with respect to GND
TP9, +27 V supply	22 ~ 32 V
TP10, +13 V supply	8 ~ 18 V
TP1, +12 V supply	10 ~ 16 V
TP5, +15 V supply	13 ~ 17 V
TP6, -15 V supply	-13 ~ -17 V

### 2) Mechanical zero adjustment of indicating meter:

So adjust the mechanical zero control (⑥ of Fig. 3-1) that the meter pointer indicates the zero point of the scale. Before this adjustment, ensure that a period of about 5 minutes has elapsed after turning-OFF the instrument power and the meter pointer has been settled.

### 3) Bias adjustment:

So adjust potentiometer R86 (Fig. 5-1) of the indicating meter drive circuit that the voltage between test point TP7 and GND becomes 0 V. Also, so adjust potentiometer R36 (Fig. 5-2) of the preamplifier of the input section that the voltage between test point TP2 and GND becomes +2.5 V.

792313



- 4) Electrical zero adjustment of indicating meter:

Set the RANGE switch (② of Fig. 3-1) at the 50 dB range, short the input terminals, and so adjust potentiometer R99 (Fig. 5-1) of the meter drive circuit that the meter (⑤ of Fig. 3-1) indicates accurately the zero point of the scale.

- 5) Sensitivity and output adjustment (see the note):

Set the RANGE switch at the -20 dB range, apply a calibration signal of 150 mV 400 Hz or 1000 Hz to the input terminal, and so adjust potentiometer R102 (Fig. 5-1) of the meter drive circuit that the meter accurately indicates the full scale position. Next, so adjust potentiometer R83 that the voltage of the output terminal becomes 1.5V.

- 6) Preamplifier (see the note):

Set the RANGE switch at the -50 dB range, apply a calibration signal of 5 mV 400 Hz to the input terminal, and so adjust potentiometer R32 of the meter drive section that the meter indicates the full scale position. Next, raise the calibration signal frequency to 400 kHz and so adjust trimmer capacitor C15 that the meter indicates the full scale position. Repeat alternately (for several times) the adjustments at 400 Hz and 400 kHz with trimmer capacitor C15 so that the meter indicates the full scale at both frequencies.

- 7) Adjustment of latter-stage attenuator (see the note):

Set the RANGE switch at the 10 dB range, apply a calibration signal of 5 V 400 Hz to the input terminal, and so adjust potentiometer R4 that the meter indicates the full scale. Next, change the calibration signal frequency to 40 kHz, and so adjust trimmer capacitor C2 that the meter indicates the full scale.

Note: For this calibration, keep the 100 kHz filter in the disconnected state (the 100 kHz pushbutton not depressed).

### 5.3 Troubleshooting

The instrument is manufactured under stringent quality control and inspection programs and normally are free of troubles. Should any failure been caused notwithstanding check the circuit voltages to locate the cause of failure.

Circuit voltages without input signal for the instrument are shown in Tables 5-1 through 5-5. (The voltages are with respect to the ground and as measured with a 11-M $\Omega$  input resistance VTVM (Kikusui Series 107)). The values are without adjustment of the AC line voltage and may differ slightly from set to set.

Pins of transistors and IC's as viewed from the bottom, are shown in Fig. 5-3.

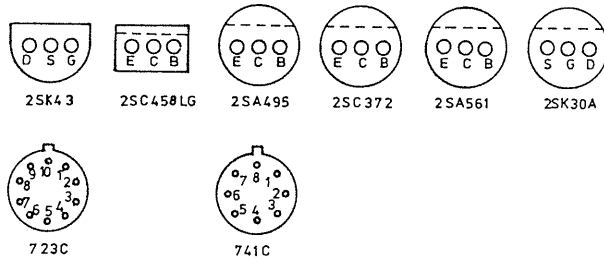

Fig. 5-3 Pins of transistors and IC's  
(bottom view)

792315

1) Preamplifier

Table 5-2

Transistor	Emitter or source	Collector or drain
Q1 2SK43	0.4 ~ 0.9 V	4 V
Q2 2SC458LG	4 V	7 V
Q3 2SC458LG	6.5 V	12 V
Q4 2SA495	6.5 V	-11 V
Q5 2SC372	-15 V	0 V
Q6 2SC372	3 V	14 V
Q7 2SA561	3 V	-15 V
QB 2SC372	12.5 V	15 V

2) Impedance converter

Table 5-3

Transistor	Emitter or source	Collector or drain
Q9 2SK30A	0.25 V	15 V
Q10 2SC372	-0.4 V	14 V

3) Main amplifier and output circuit

Table 5-4

Transistor	Emitter	Collector
Q11 2SC372	0.1 V	6 V
Q12 2SC372	6.5 V	11 V
Q13 2SA495	6.5 V	0.5 V
Q14 2SA561	12 V	4 V

792316

4) Meter drive circuit

Table 5-5

Transistor	Emitter	Collector
Q15 2SA495	-0.04 V	-12 V
Q16 2SC372	-12 V	0.5 V

MC3 No. 6 pin (with input 0 V) ..... Approx. 0 V

5) Power supply (See Fig. 5-1)

Table 5-6

IC	Pin No. 4
MC1 723C	6.8 ~ 7.8 V
MC2 723C	6.8 ~ 7.8 V

792317